

Dimensions and weights of foundry alloys

We are producing two types of foundry alloys, continuous cast and mould cast ingots.

Continuous cast ingots

Dimension	75 x 54 x 756 (648)	mm
Product weight	7.5 (6.5) kg	
Bundle weight	580 - 1100 kg	
Bundle strapping	polyester, steel or aluminium tape	

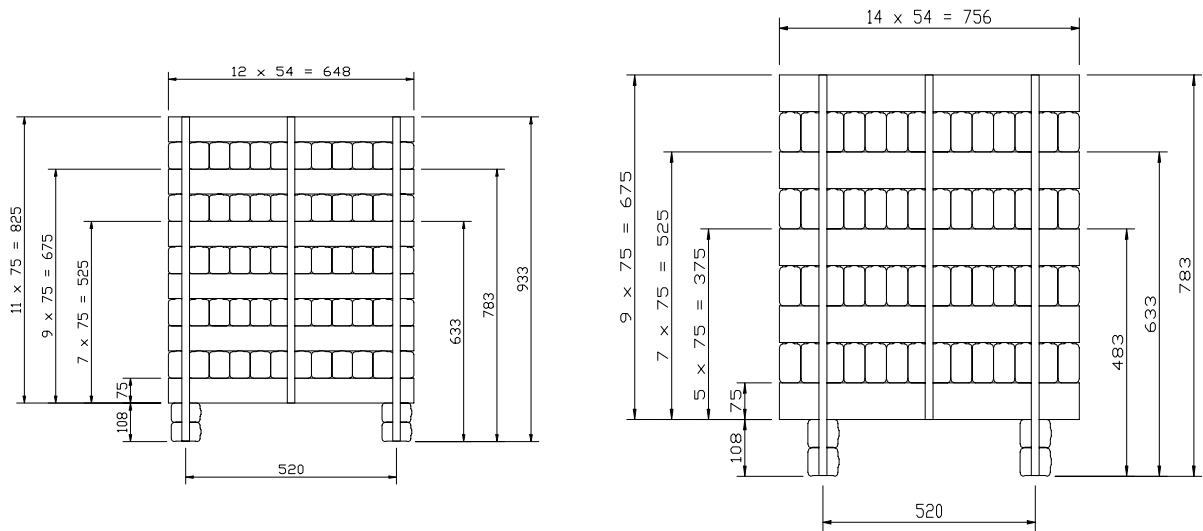

Continuous cast ingots 54 x 75 / L=648 mm (weight ~ 6,5 kg)				
Bundle weight (kg)	Total bundle weight (mm)	Rows x Ingots	Footing ingots	Total number of ingots (with footing)
588	633	7 x 12	4	88
748	783	9 x 12	4	112
909*	933*	11 x 12	4	136

Continuous cast ingots 54 x 75 / L=756 mm (weight ~ 7,5 kg)				
Bundle weight (kg)	Total bundle weight (mm)	Rows x Ingots	Footing ingots	Total number of ingots (with footing)
577	483	5 x 14	4	74
795	633	7 x 14	4	102
1013*	783*	9 x 14	4	130

* Standard

Mould cast ingots

Dimension 120 x 50 x 620 mm
 Product weight 7 kg
 Bundle weight 490 kg (single) 980 (double)
 Bundle strapping polyester, steel or aluminium tape

Double bundle*

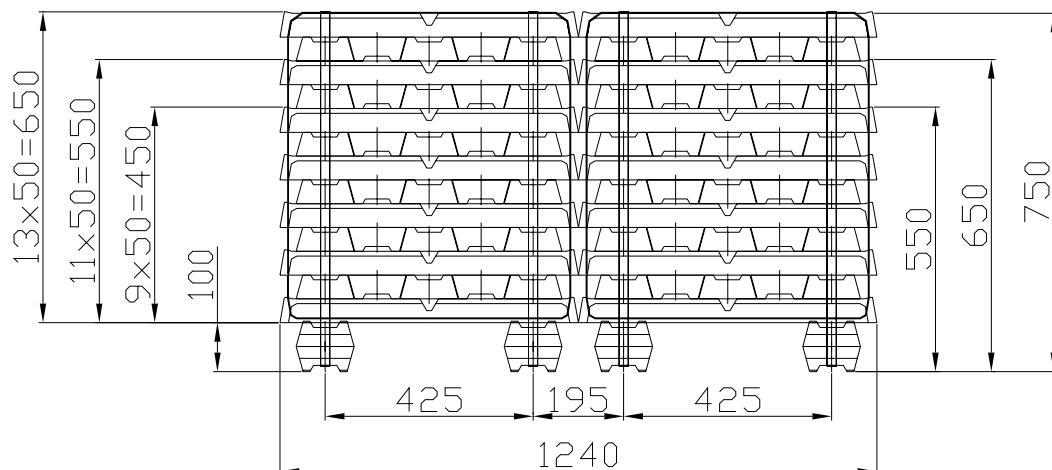

Mould cast ingots 120 x 50 x 620 mm (weight ~ 7 kg)				
Bundle weight (kg)	Total bundle weight (mm)	Rows x Ingots x Bundle no.	Footing ingots	Total number of ingots (with footing)
686	550	9 x 5 x 2	8	98
826	650	11 x 5 x 2	8	118
966*	750*	13 x 5 x 2	8	138

*Standard

Single bundle

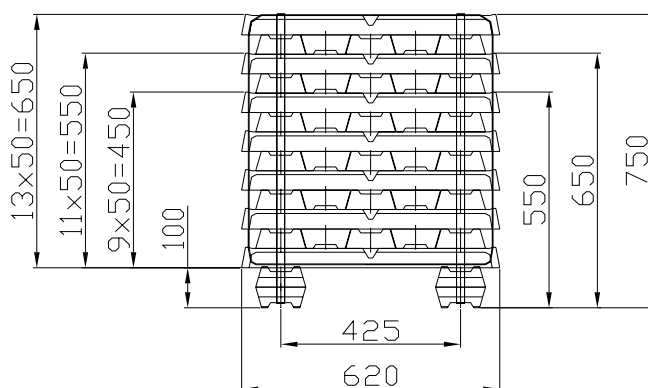

Mould cast ingots 120 x 50 x 620 mm (weight ~ 7 kg)				
Bundle weight (kg)	Total bundle weight (mm)	Rows x Ingots	Footing ingots	Total number of ingots (with footing)
343	550	9 x 5	4	49
413	650	11 x 5	4	59
483*	750*	13 x 5	4	69